

A Versatile Workstation for Fiber Fusion Applications

The CW-5000 workstation is designed to fabricate a wide range of fused fiber optic products, including biconical tapered fused couplers, single fiber tapering, and fiber processing.

Its structural design, optional platforms, and intelligent automatic control make this workstation a highly useful machine for fiber fusion-related manufacturing and research.

The included software streamlines the production process and offers a wide range of customization options to assist in producing the exact products you require.

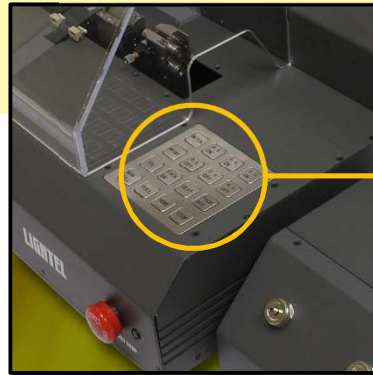
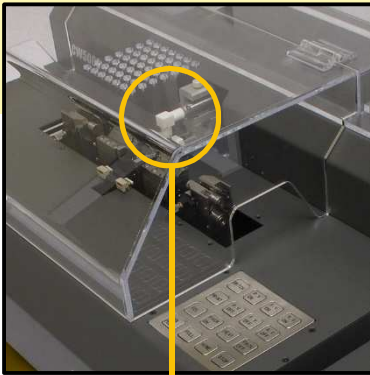

Features

- Control panel provides easy regulation of 15 frequent actions
- Central heating region, with torch, vacuum holders, and epoxy curing heaters
- Software provides real-time fusion status including pulling length, power readings, coupling ratio, and excess loss
- Software supports multiple operation modes for narrowband and wideband couplers, WDMs, PM couplers, and more

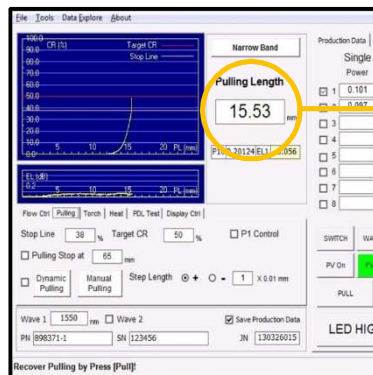
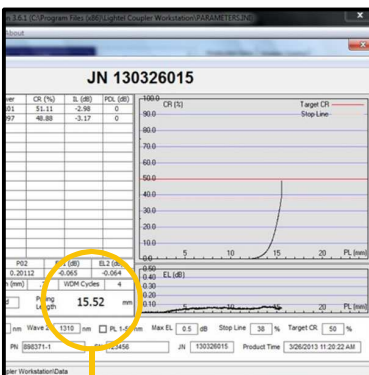

→ Standard Hardware Configuration

- Unit installed with Base Platform for fabricating standard 1x2 and 2x2 fused devices
- Six motors with programmable motion control
- High-precision pulling (90mm total travel range/45mm each side)
- Hydrogen torch nozzle, I.D. 10mm and oxygen diffuser with three-dimensional freedom of movement
- Vacuum fiber holders and vacuum gauge reading meters
- Built-in digital mass flow controllers for controlling hydrogen and oxygen respectively
- Open-loop pre-packaging curing system
- Control panel with 15 buttons
- Windshield protection cover
- Emergency button for safety
- 2-channel digital optical power meter module
- Vacuum pump module
- Computer with LCD monitor

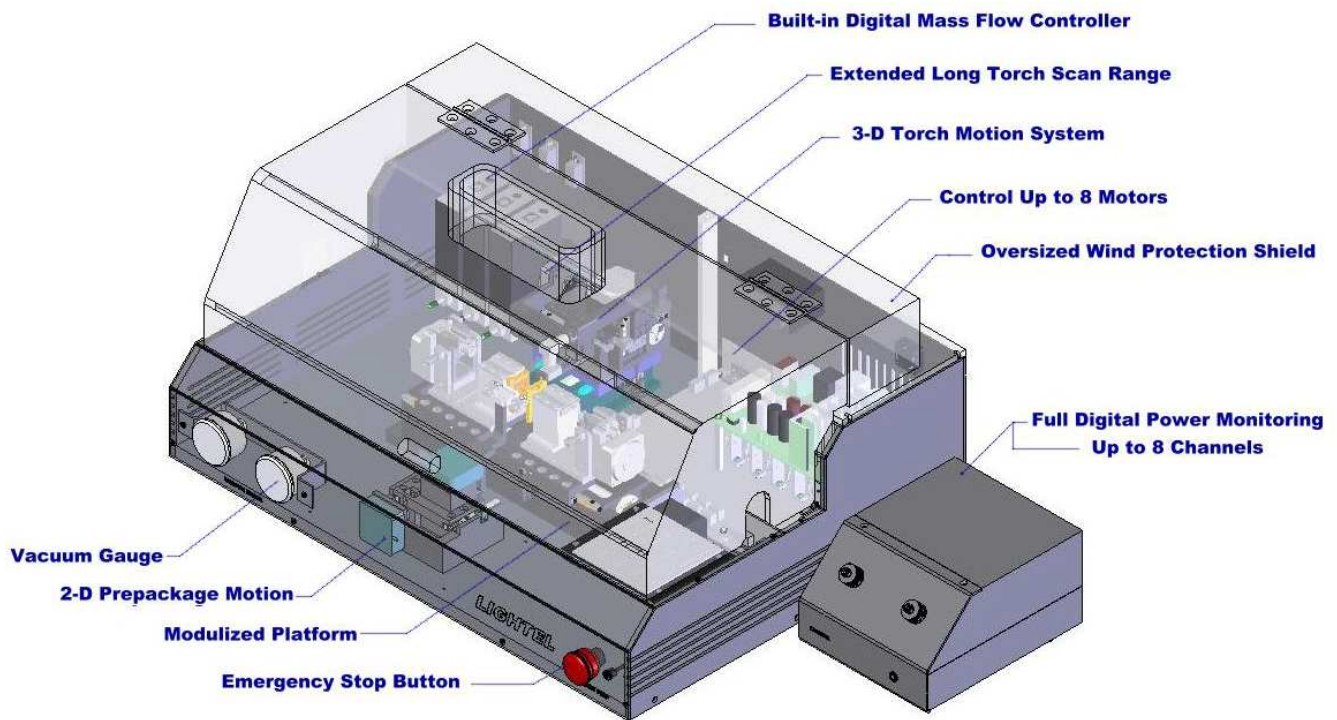

**PM platform with optional oversized Wind Protection Shield shown
For Illustration Purpose only, Actual product may vary**

→ Hardware Options

- Full line of hydrogen torch nozzles (ID from 6mm up to 12mm)
- Extended pulling-stage, up to 200mm total travel range
- Extended torch scanning range, up to 100mm (standard 45mm)
- Extended size of windshield protection cover
- Digital optical power with extra monitoring channel, up to 8 channels in total
- Closed-loop prepackaging curing system for curing temperature monitoring and control
- 1x3 upgrade, with special 1x3 vacuum chuck bases, additional channel on power meter and extra bare-fiber adapter
- Hybrid torch system with upper hydrogen nozzle and lower hydrogen/oxygen nozzles for high fusion temperature
- Extra built-in digital mass flow controller when using the hybrid torch system

➔ Platform Options

The CW-5000's modular design makes it highly flexible for a wide range of tasks. Six Interchangeable platform options are available, covering almost all current fused fiber applications. Each can be custom-configured to meet special needs.

Base Platform For 1x2, 2x2 coupler fabrications or various single fiber processing (support for twisted-fiber loading only)

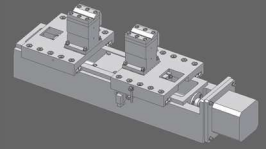

Base Plus (Parallel) Platform For 1x2, 2x2, 1x3 coupler fabrications or various single fiber processing (support for twisted fiber loading and parallel fiber loading). Includes Base Platform functionality.

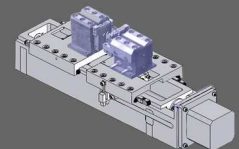

Rotation Platform For 1x2 and 2x2 coupler fabrication. (Including a pair of manual rotators for fiber rotation after fusion. This is typically used for fine-tuning performance, such as the coupling/splitting ratio, WDM channel isolation, etc.). Includes Base Platform functionality.

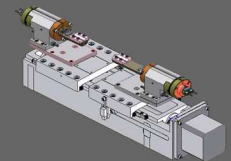

Polarization Maintaining (PM) Platform A special platform for PM products. It includes two additional motors for PM fiber orientation alignment as well as special software control.

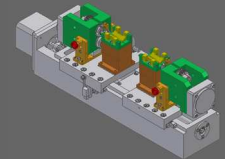

Fiber Bundle Platform Handle multiple fibers (max diameter 400um each, up to N=7), ideal for multimode fiber bundle fabrication. Consult with Lightel sales representative for more information.

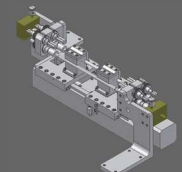

1x4 Platform Dedicated for 1x4 single-fusion splitters. Handles 4 or 5 fibers.

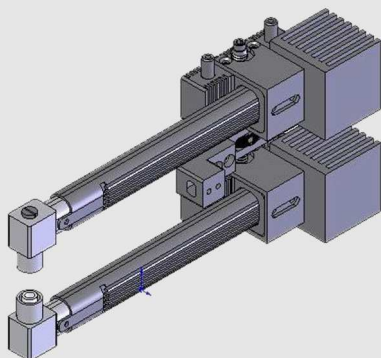
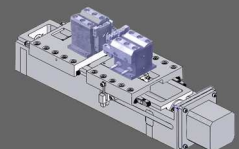

Dual Head Torch



8 Channel Power Meter



Optional Torch Heads & Diffusers

→ Software Features

- Windows-based application software provides a user-friendly interface, which updates real-time fusion status; including the pulling length, power readings, coupler's coupling ratio, and excess loss. Two evolution curves of the coupling ratio and the excess loss help for easy visual monitoring.
- Programmable fusion-parameter profiles are provided for dynamic control of the fusion process. The variable parameters include pulling speed, torch scanning speed, torch height, hydrogen gas flow rate, and oxygen gas flow rate. This is a useful feature for users to fine-tune their fusion recipes.
- Allows user to save all the process parameters and product results for each fusion attempt. Data Explore stores each job's details for future retrieval and use with the original interface.
- Supports multiple operation modes for various products, such as narrow-band couplers, wideband couplers, WDM couplers, PM couplers, single fiber or fiber-bundle tapers.
- Supports multiple pulling methods, such as standard pulling, dynamic pulling, manual pulling.
- A user-friendly tool of motor testing and panel button testing is very useful for maintenance and troubleshooting.
- A closed-loop epoxy-curing system (optional) provides two independent feedback/control loops (for the left and right heating elements, respectively), making the curing temperature of both heating elements follow a user-predefined heating profile.
- Includes special features for processing non-standard couplers, such as PM couplers, fiber bundles, etc.



Main Interface

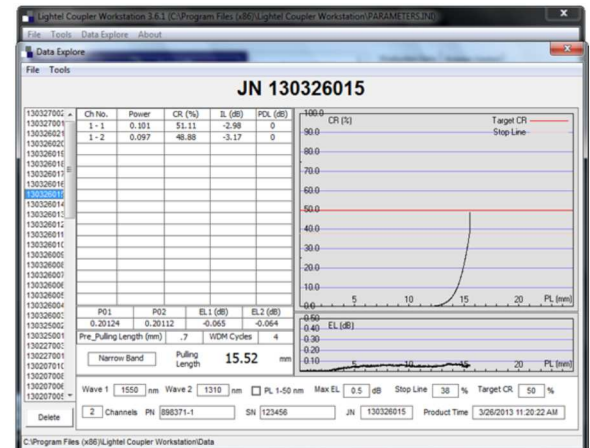

Unit Fabrication Report

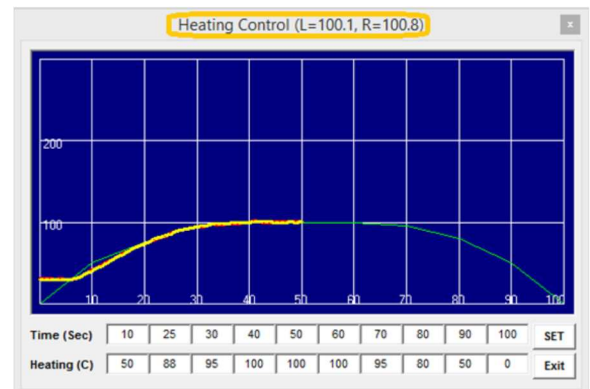

Closed Loop Epoxy Curing Profile

→ Specifications

Dimensions: 21.65" x 16" x 9.65" (550 x 405 x 245mm)
 Weight: 70lb (31.5kg) Approx.
 Power: 100-240V, 50/60Hz, 150Watt